

KIT CONTENTS

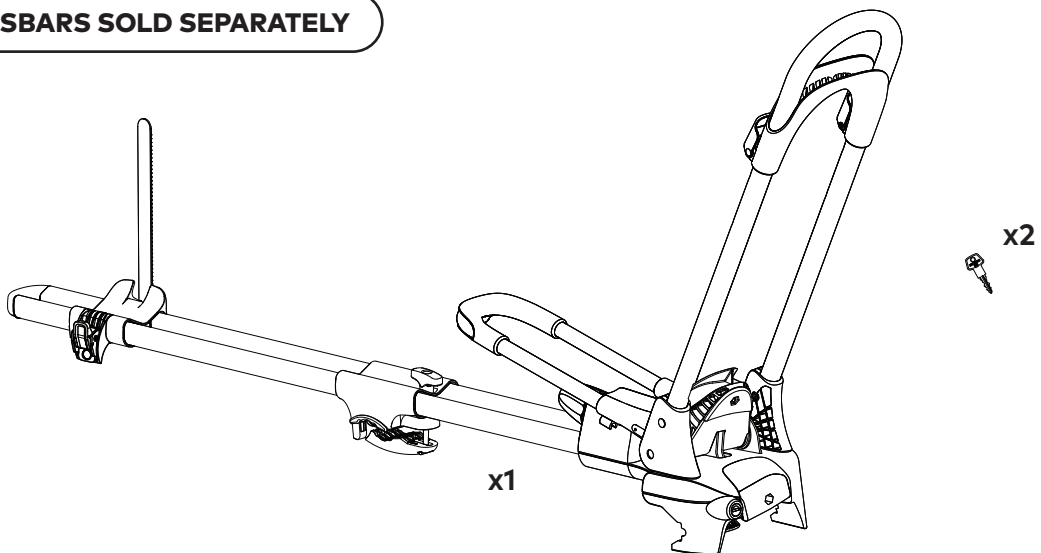





CROSSBARS SOLD SEPARATELY

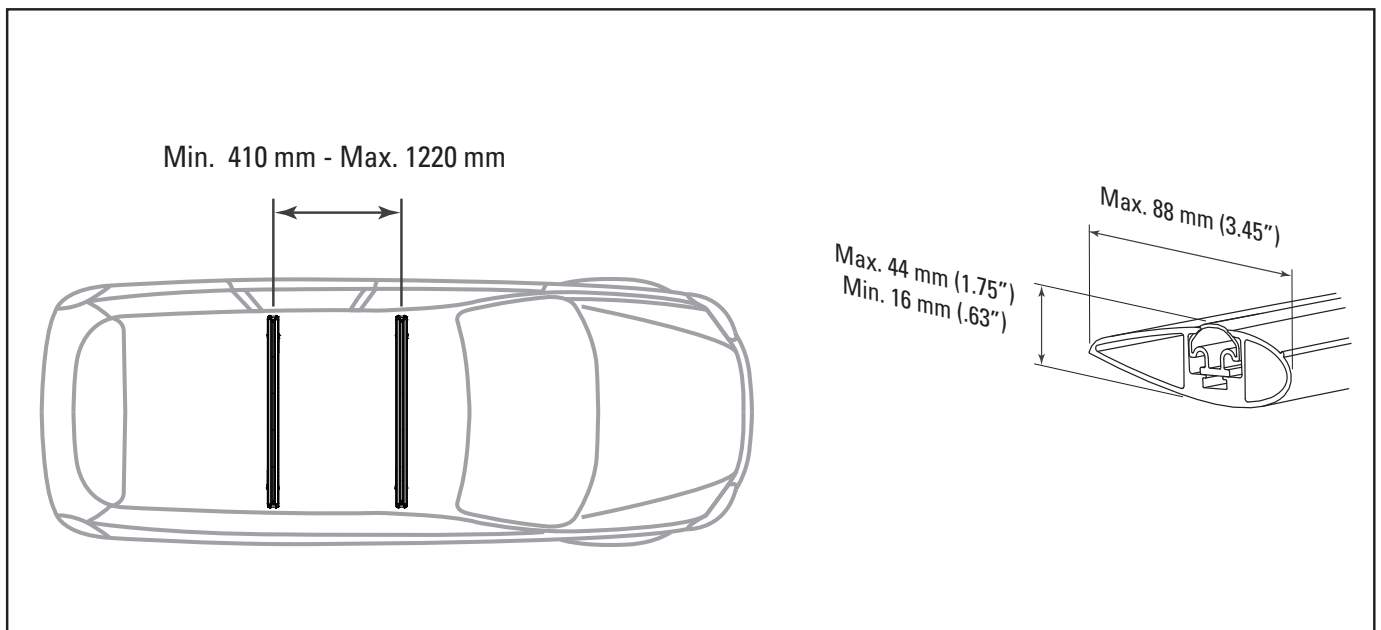

FIRST TIME INSTALLATION

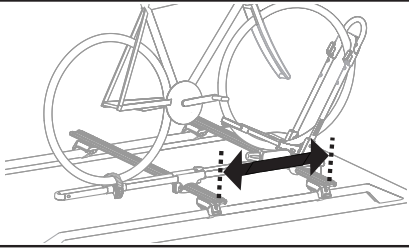
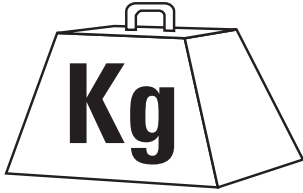
- Please read instructions carefully before installation.
- Check the contents of kit. Contact your YAKIMA dealer if any parts appear missing or damaged.
- Clean your roof rack/platform prior to fitting the YAKIMA FrontLoader.
- Place these instructions in the vehicle's glove box after installation is complete.



	
<p>410mm - 460mm</p>	<p>13.6Kg /  2x  MAX.</p>
<p>460mm - 1220mm</p>	<p>18.1Kg / </p>

INSTALLATION

1

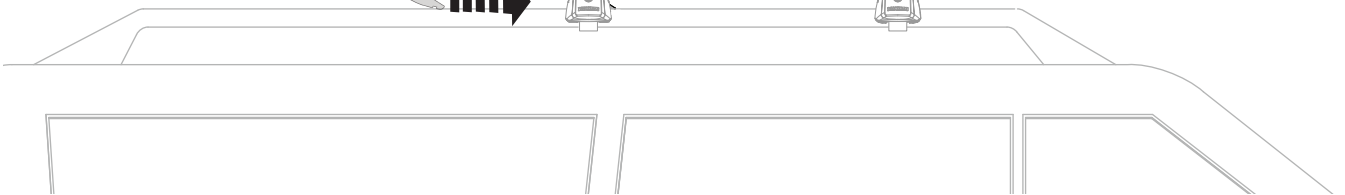
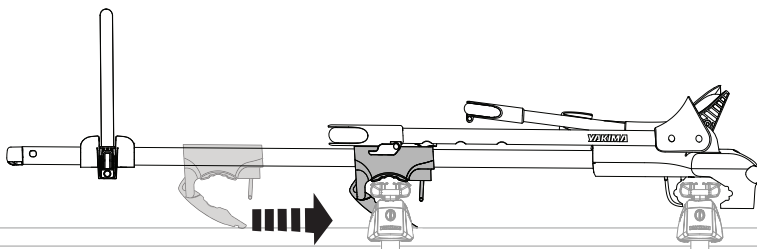
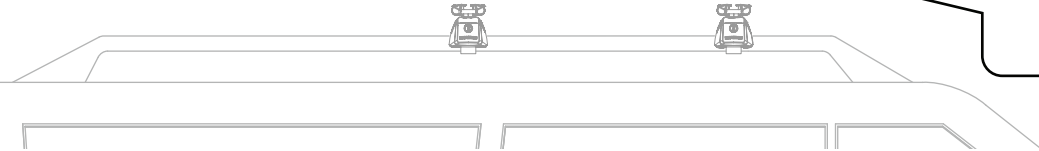
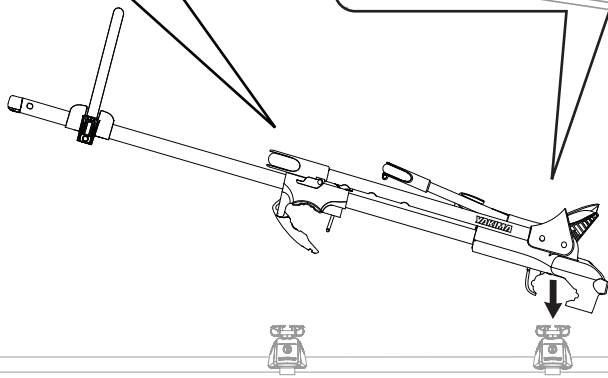
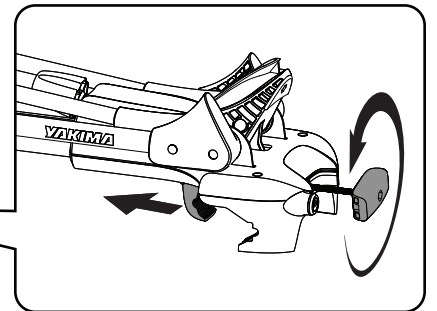
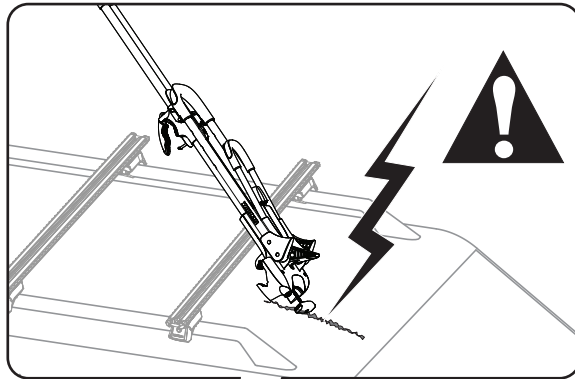
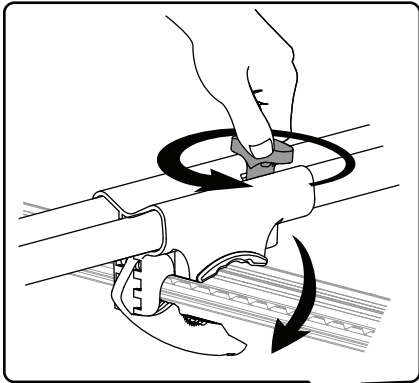
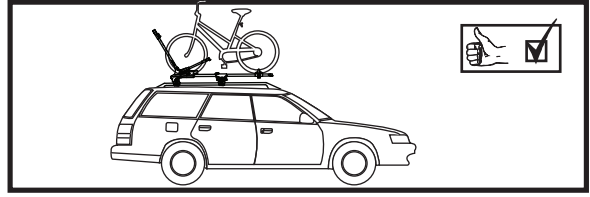
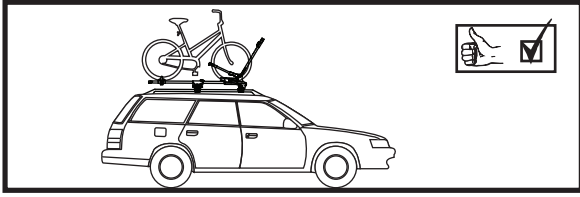

2

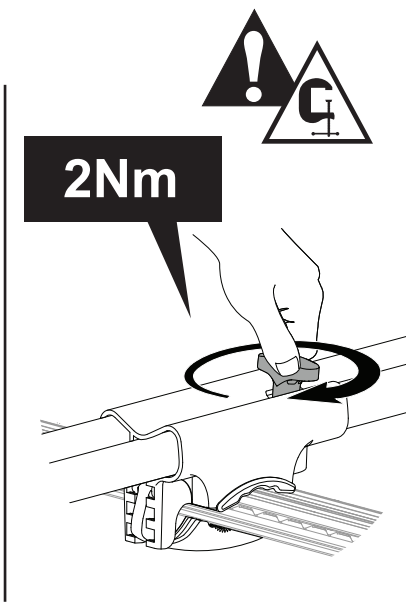
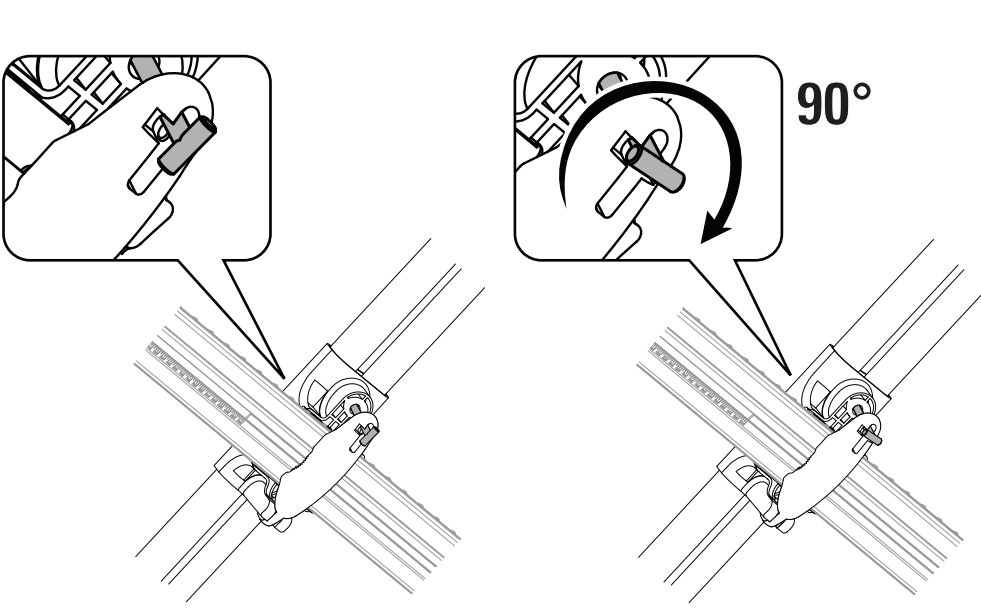
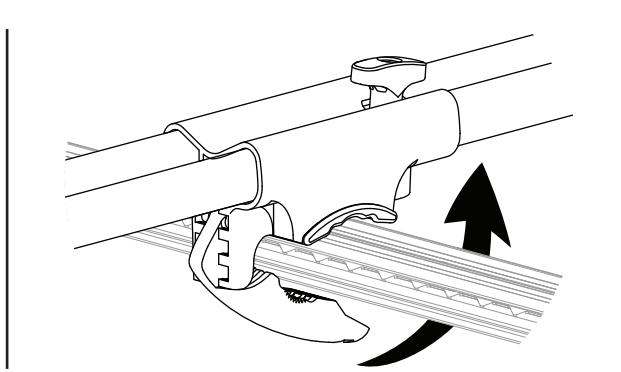
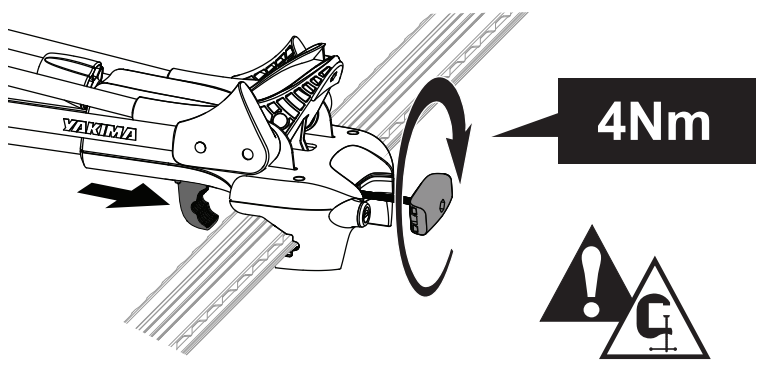
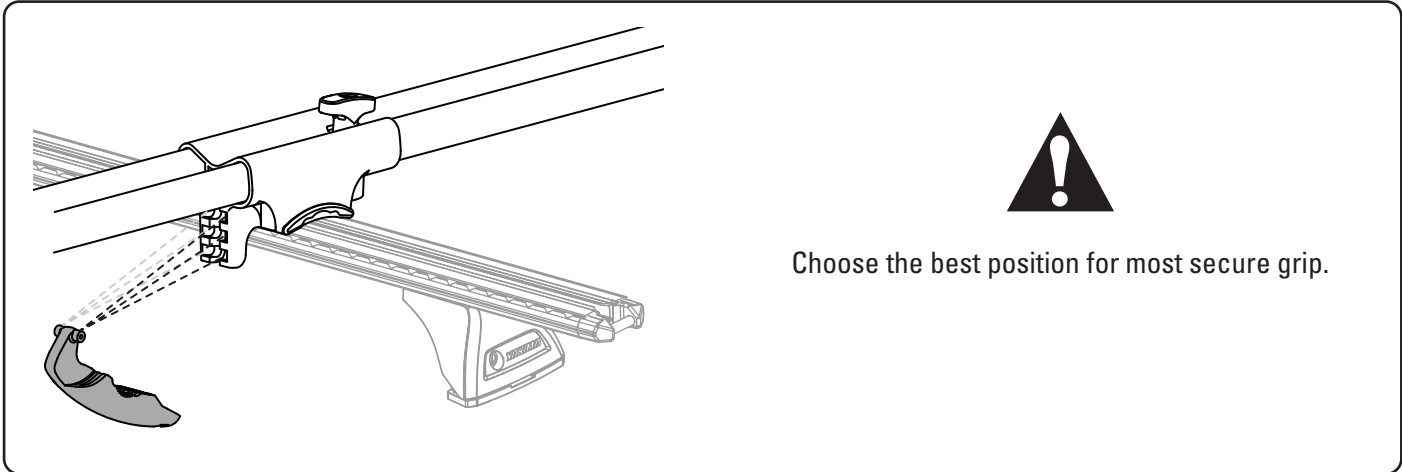
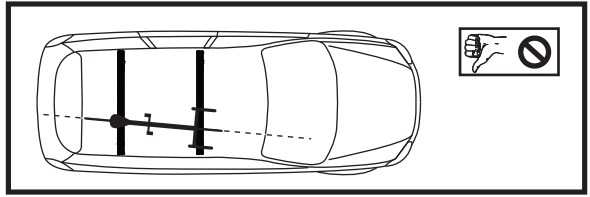
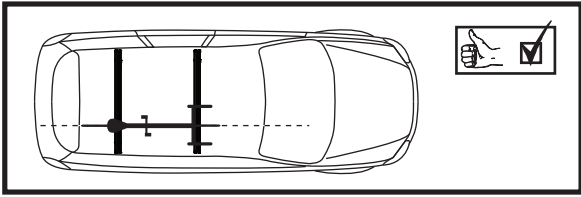

OPTIONAL

- Orient buckle for easiest access when loading or unloading.

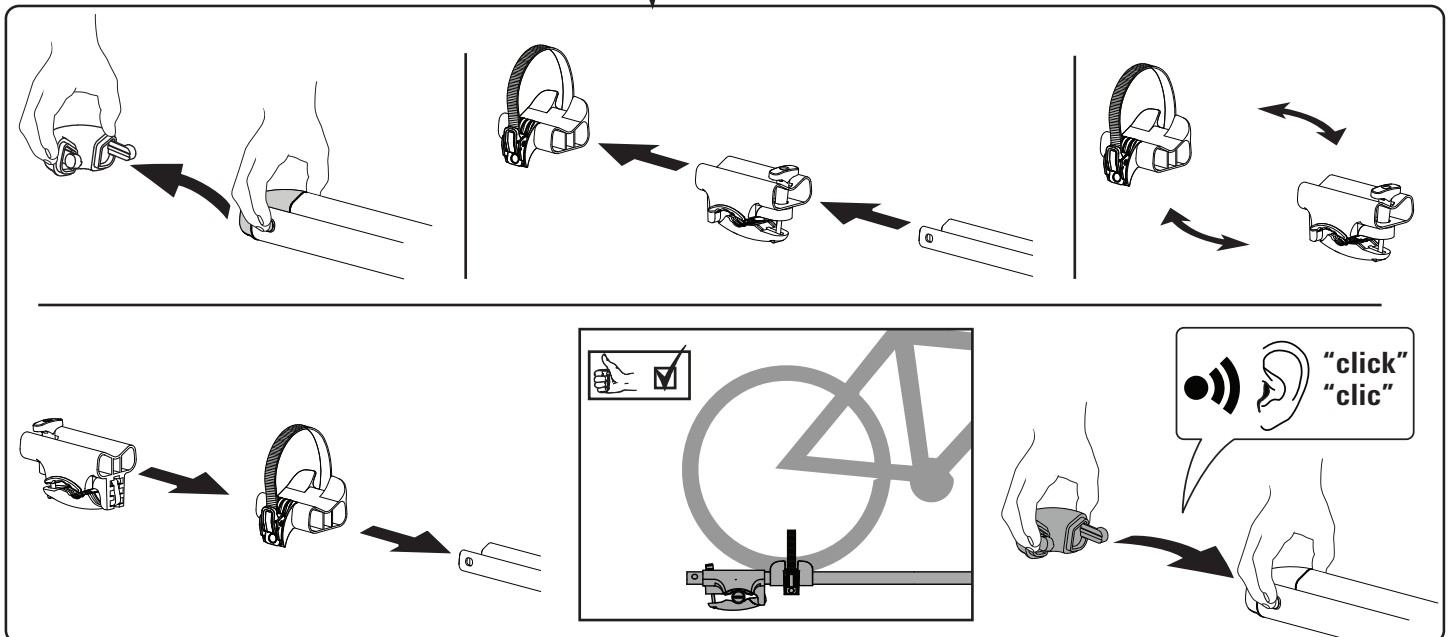
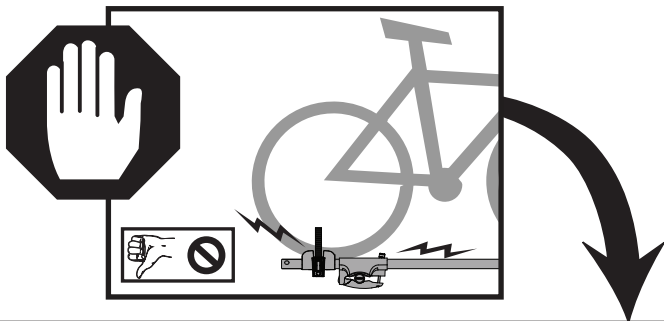
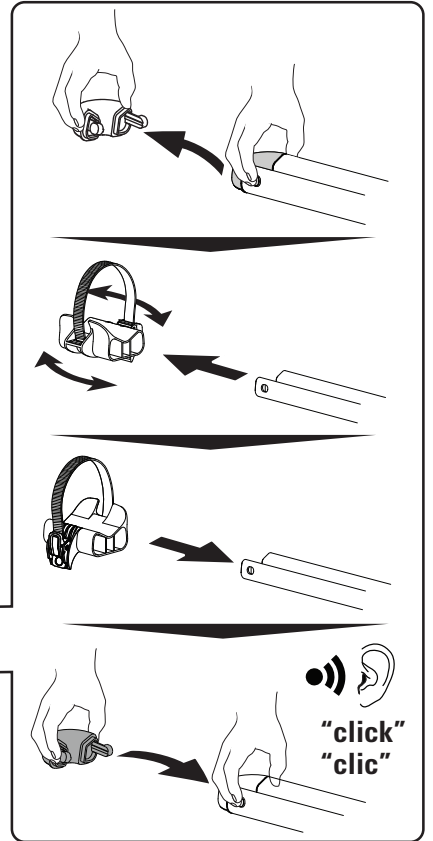
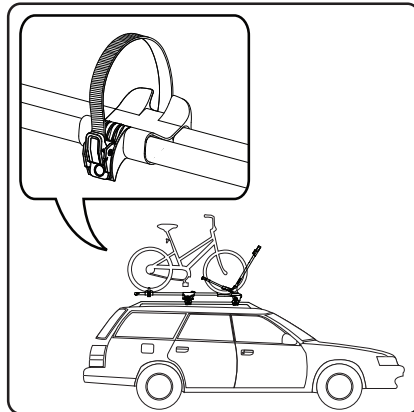
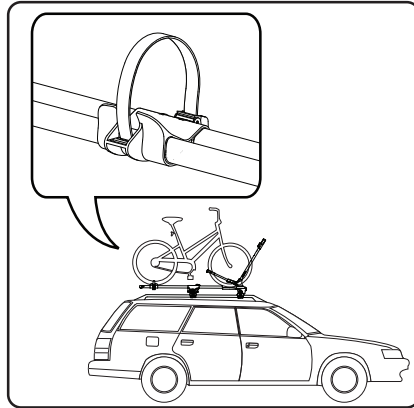

3

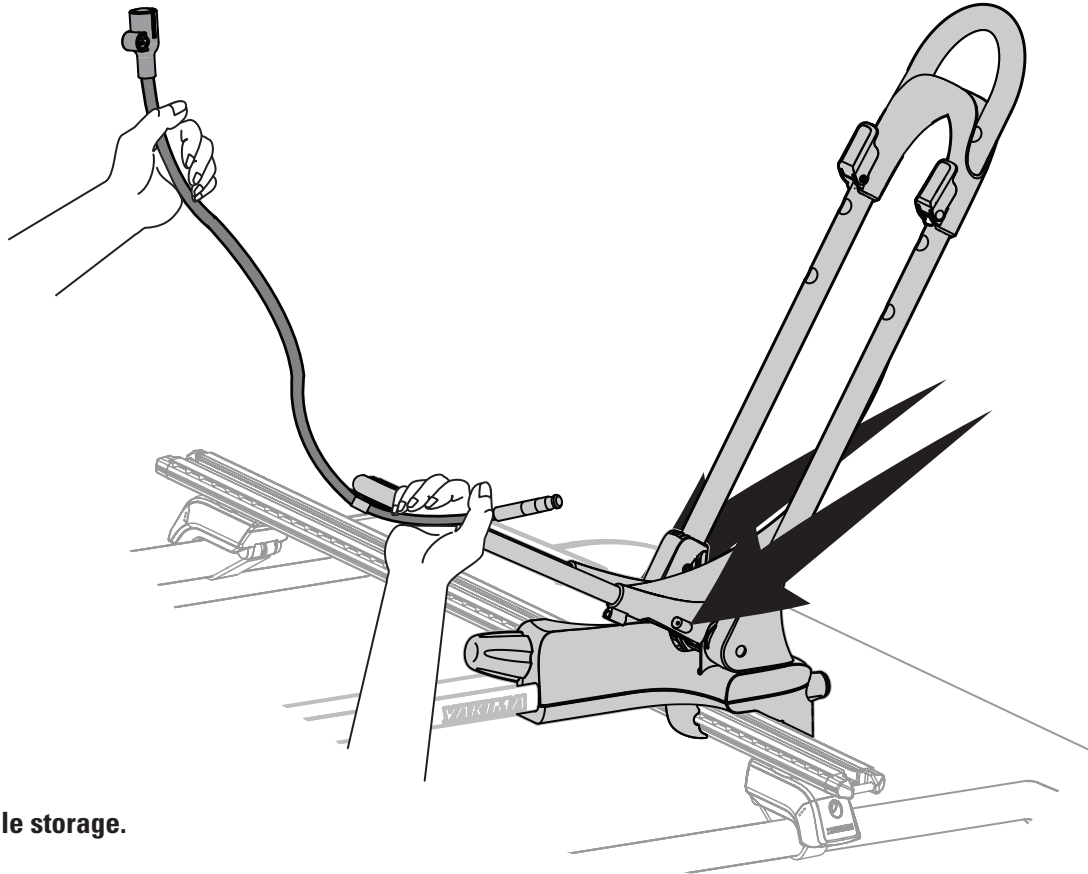

Lock cable storage.

NOTE: Front knob must be in horizontal position to lock.

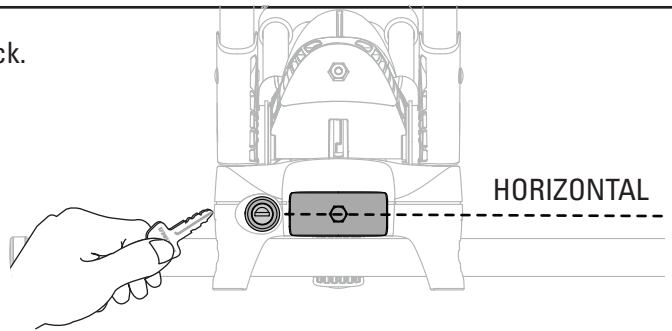

LOADING

4

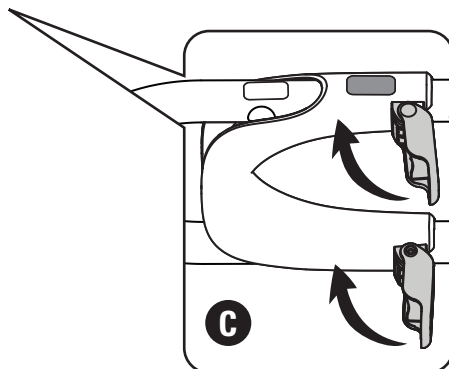
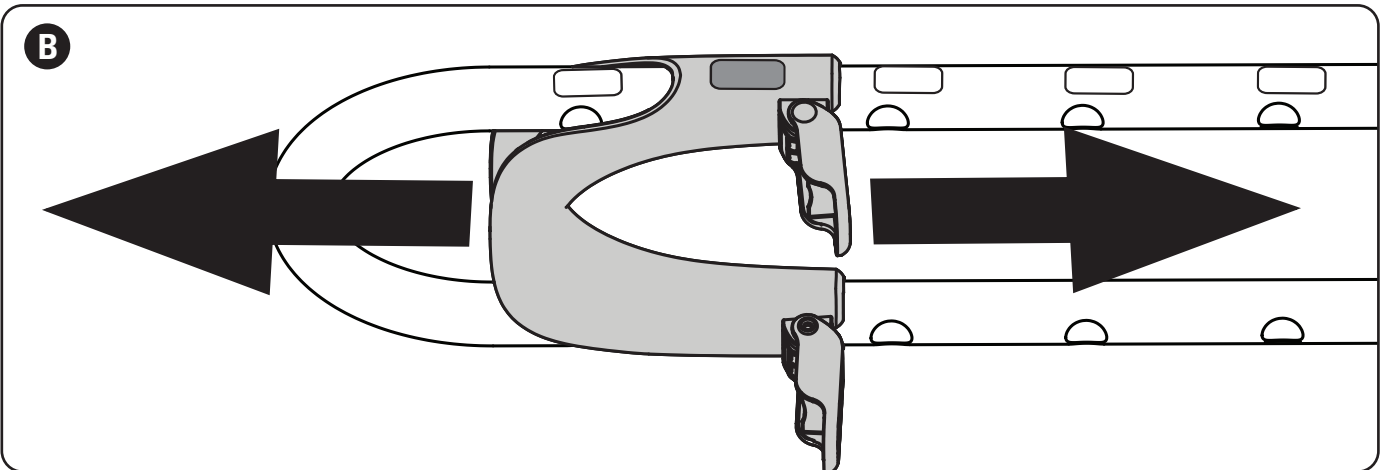
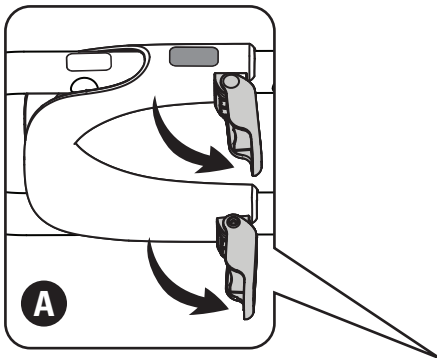
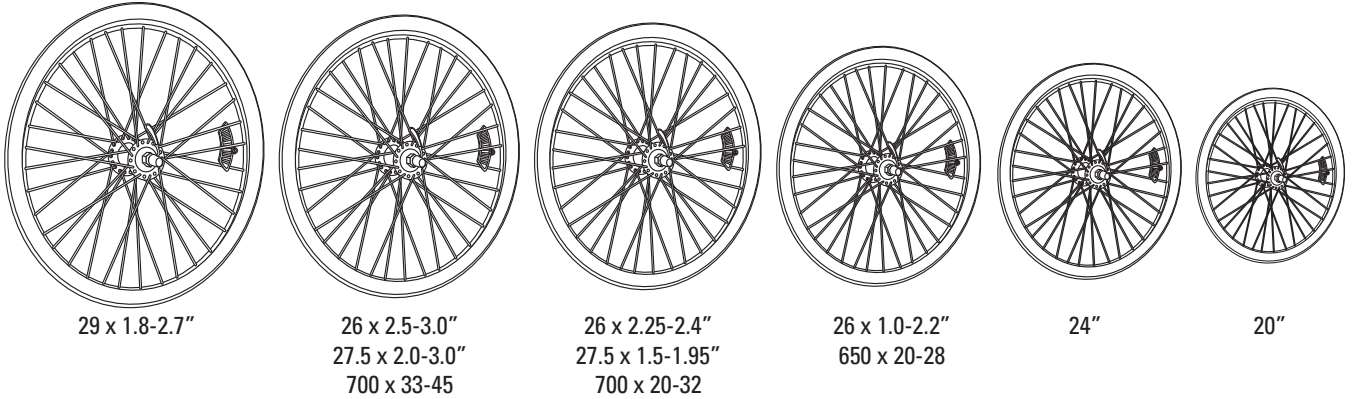

5

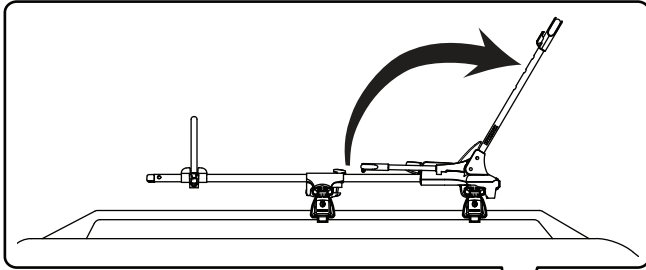

Tyre must be fully inflated.

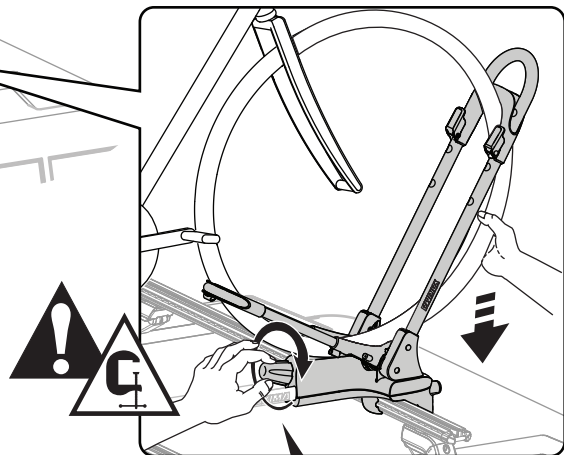
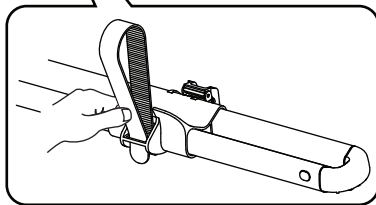
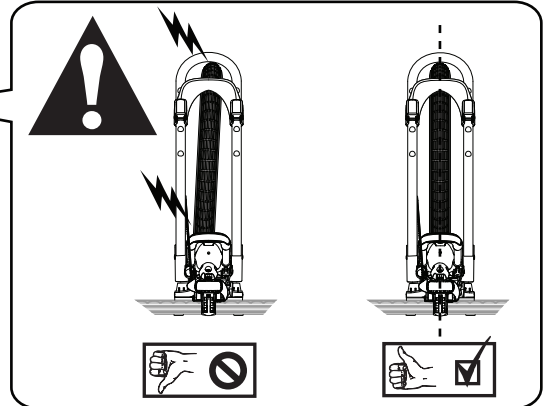
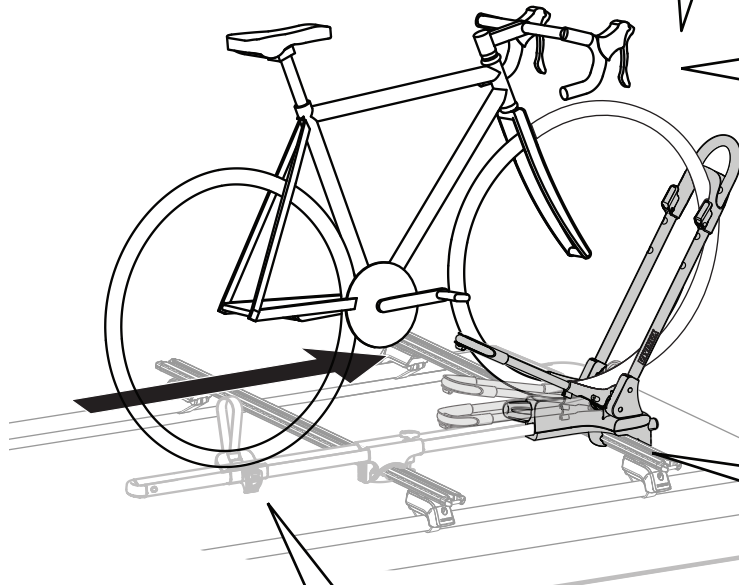

3Nm

6

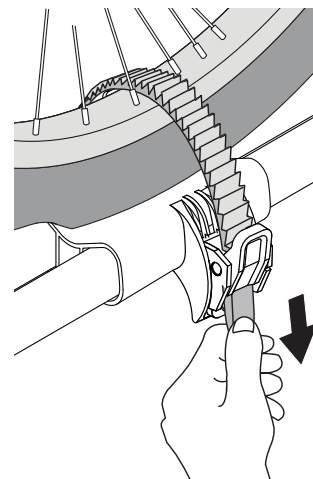
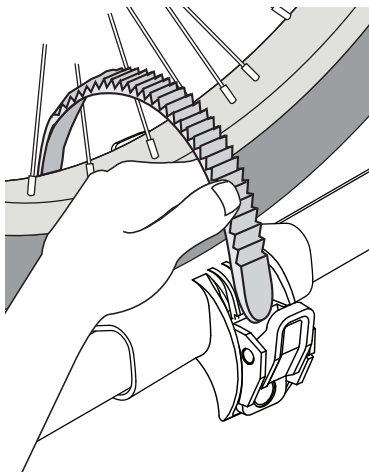

7

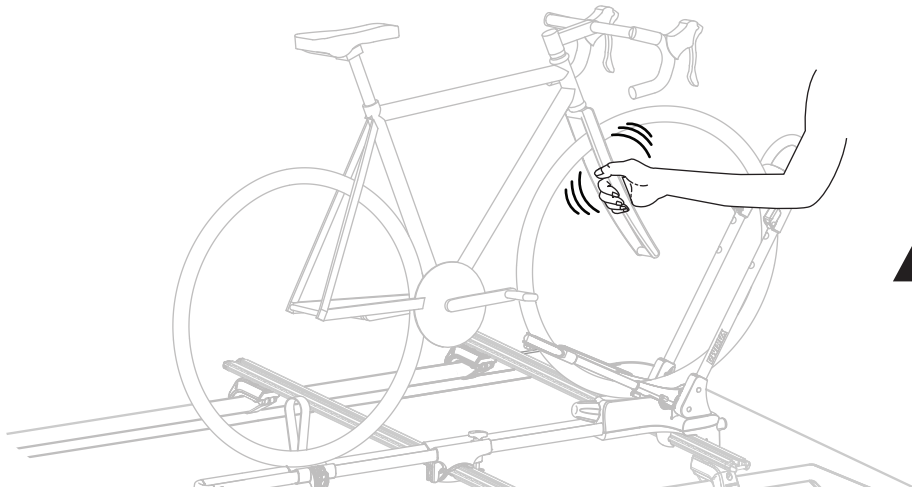

8

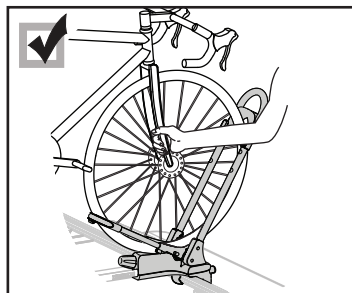
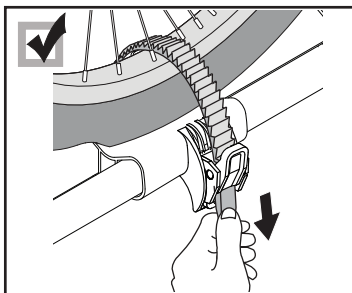
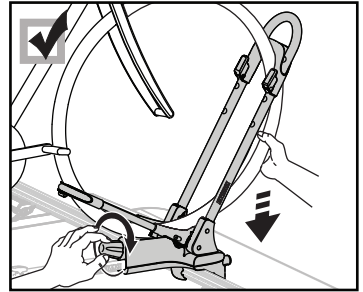
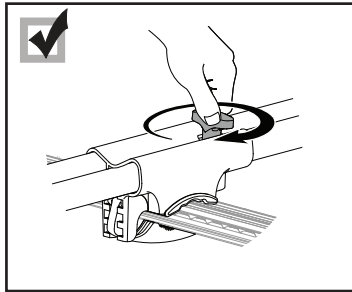
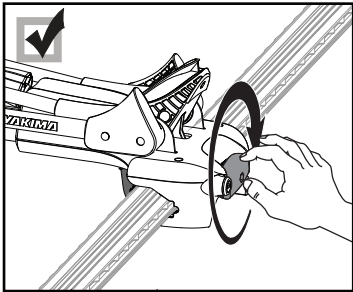
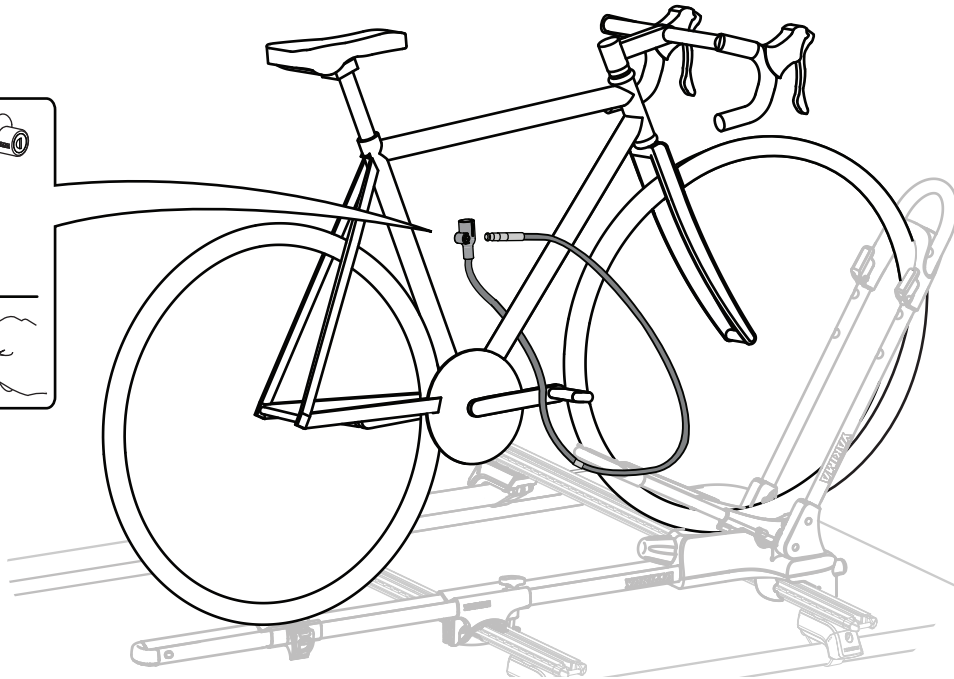
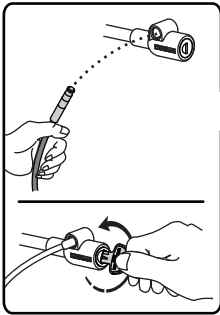

UNLOADING

9

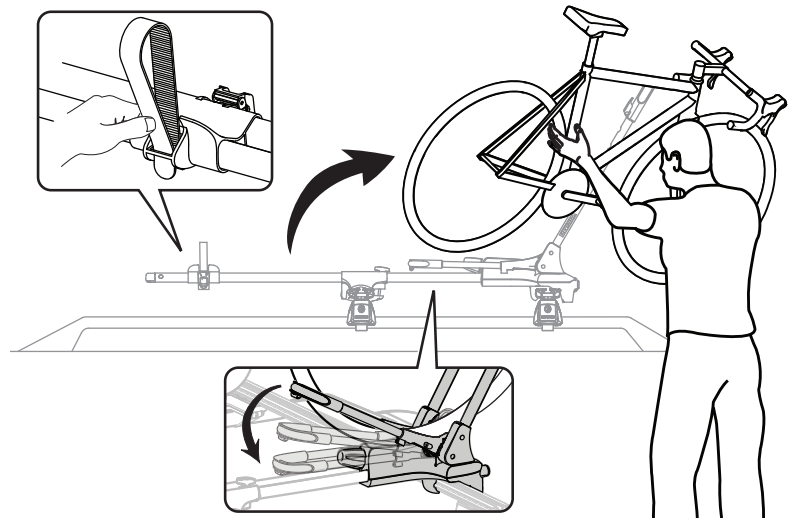
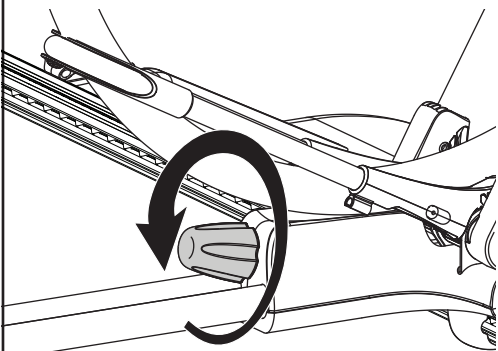
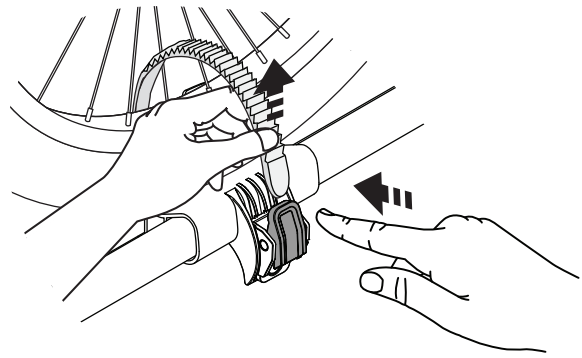
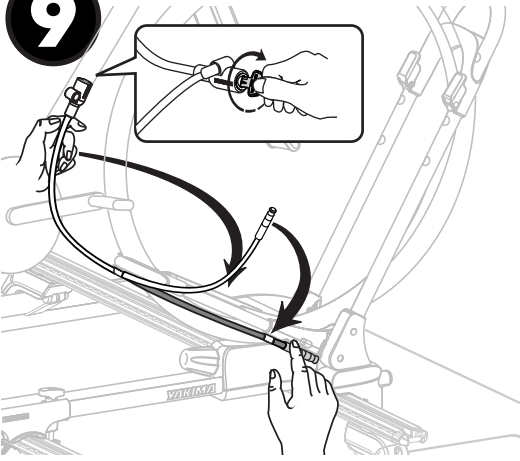

REMOVAL

10

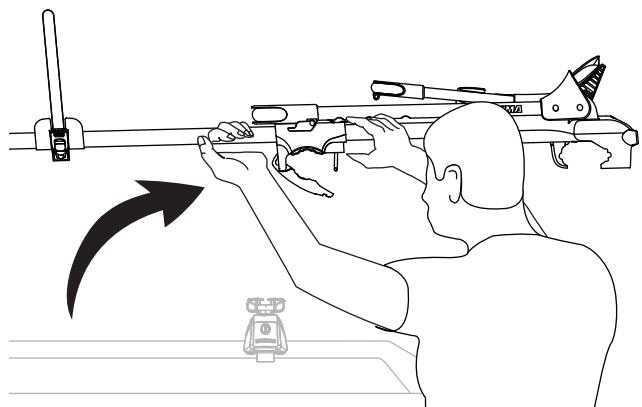
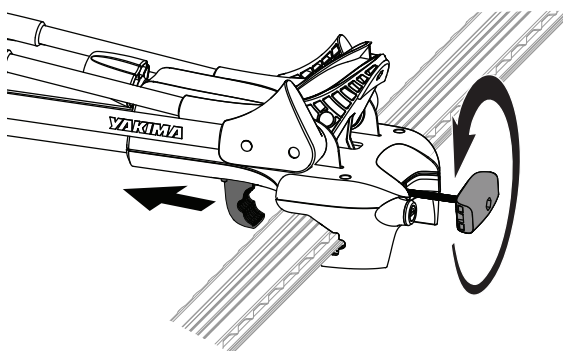
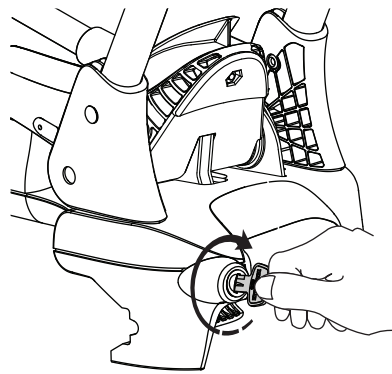
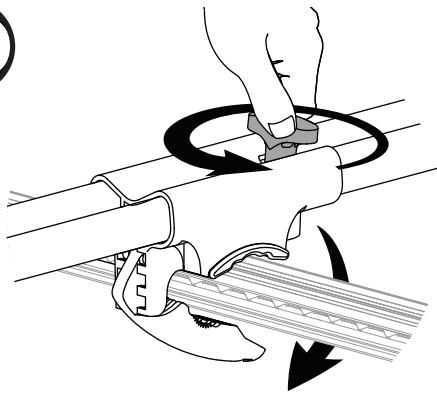

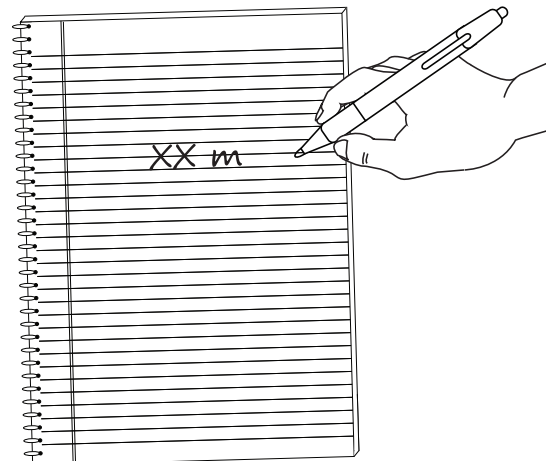
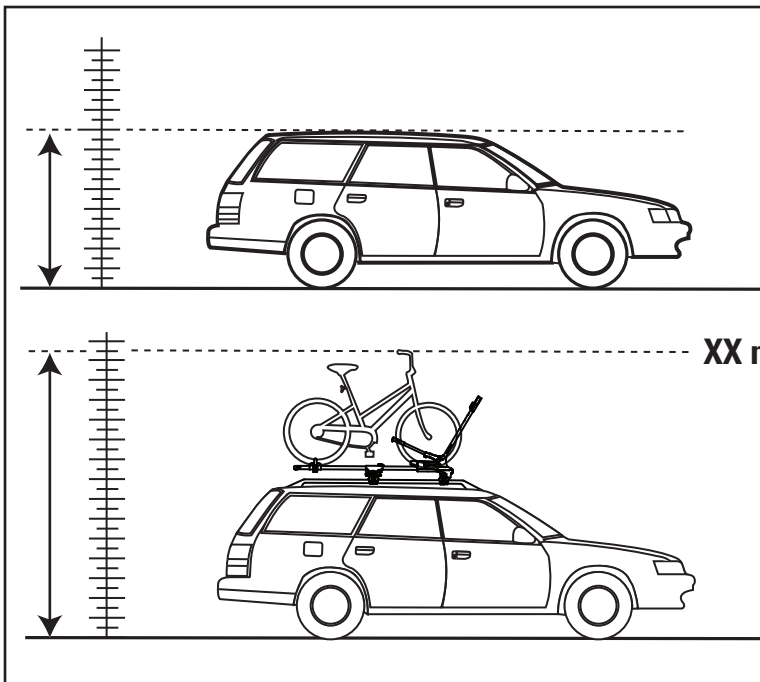
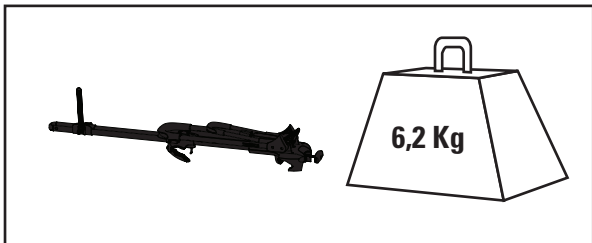
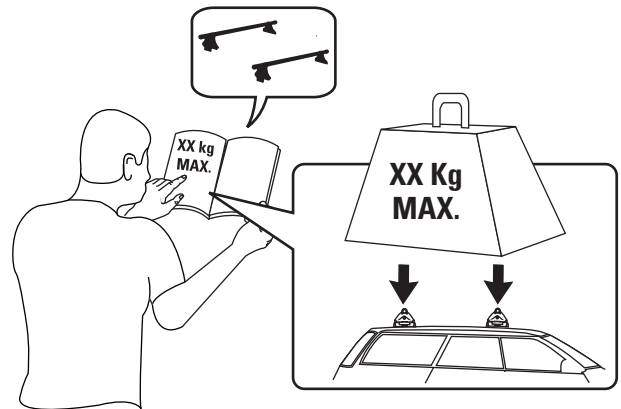
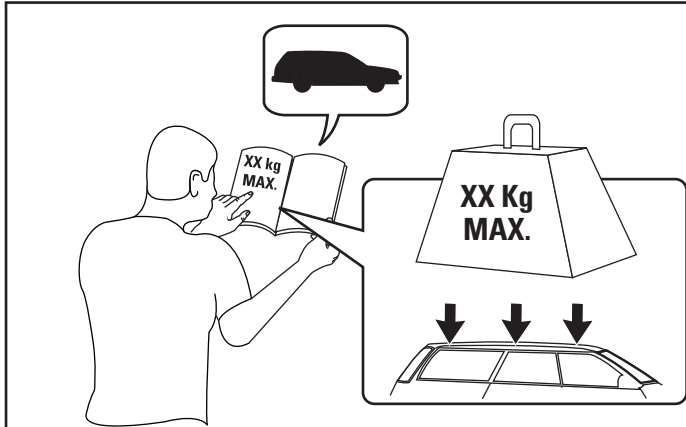
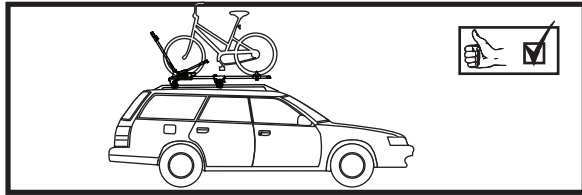
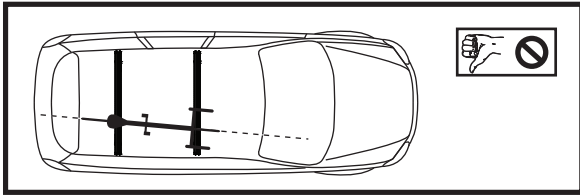
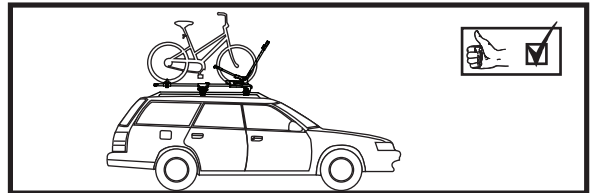
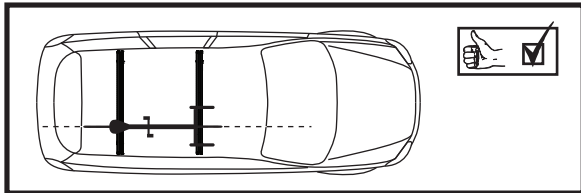

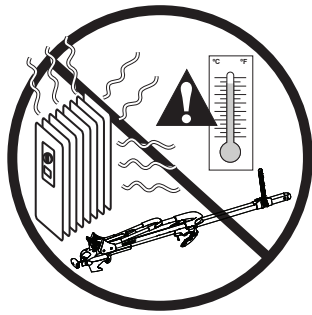
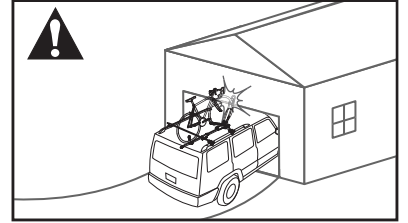
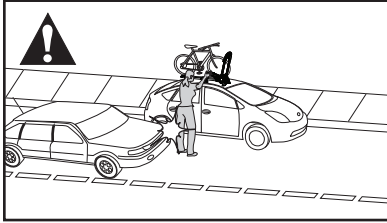
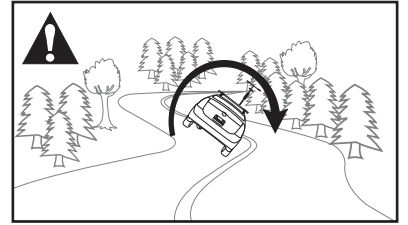
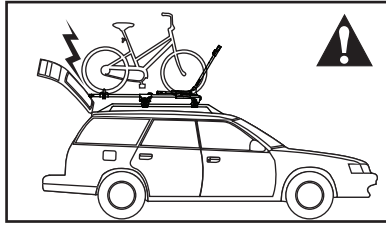
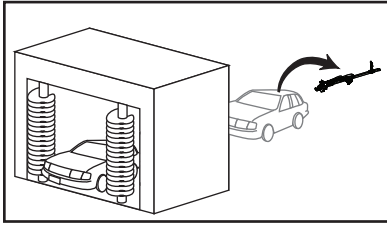

This page intentionally left blank



www.yakima.com.au
www.yakima.co.nz
www.yakima.com
www.yakima.eu

YAKIMA AUSTRALIA PTY LTD

17 Hinkler Court
Brendale, QLD 4500
Australia
1800 143 548
yakimaglobal.com

YAKIMA PRODUCTS, INC.

4101 Kruse Way
Lake Oswego, OR
97035-2541
USA
888 925 4621
yakima.com/support